

Box: PLOCK 1

BIKE	HONDA CBF 1000	PART NO.	RHA - 106
YEAR	2010 - Current	FIT KITS	Z039.20447
NOTES	When removing O.E. system:- only disconnect cables from servo motor, DO NOT unplug or remove servo.	FEATURES	DB KILLER Z038.10043(V)

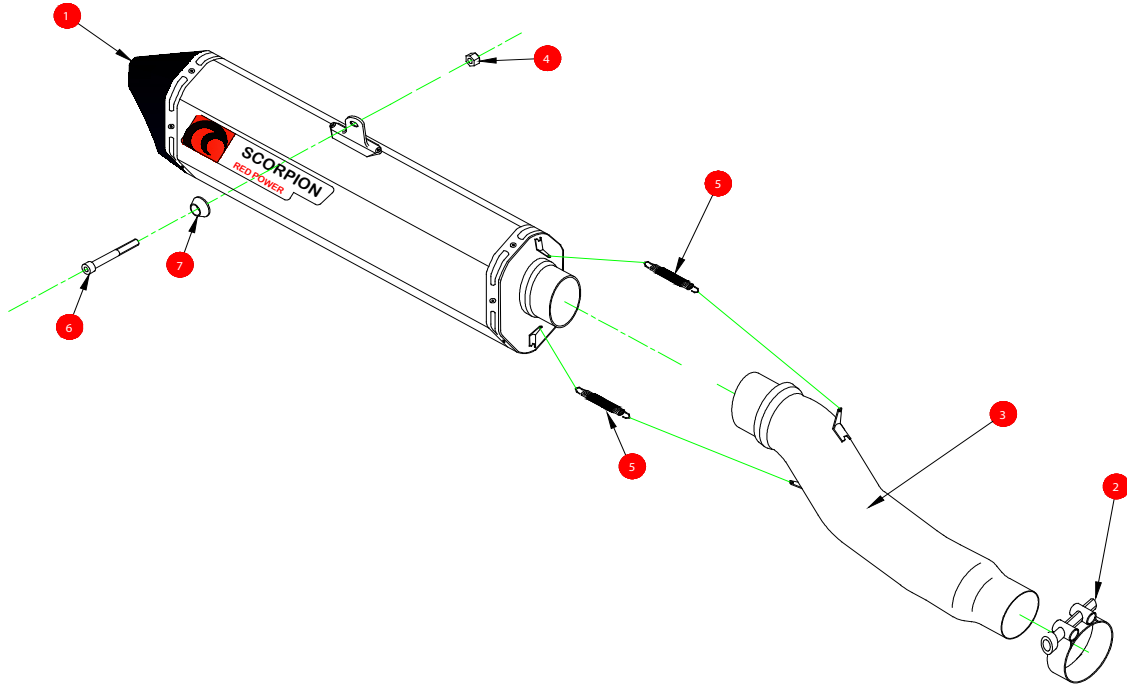

- | | |
|--|--|
| 1 400mm Serket Silencer RSC227 | 7 Aluminium Bolt Finisher (Z026.20068) |
| 2 51-55mm Band Clamps (Z016.10002) | |
| 3 Connecting Pipe CP 674 | |
| 4 M8 Nyloc Nut (Z017.10062) | |
| 5 2 x Rubber Coated Springs (Z028.10030) | |
| 6 M8x60mm Cap Head Bolt (Z017.10080) | |

E-MARK	BSAU 193a 1990/t3
ISSUE NO.	3
DATE	10/1016
AUTHORISED	S.Jackson
CHECKED	

NOTE: ENSURE SCORPION SYSTEM IS CLEAR OF MOVING PARTS AND ALL ORIGINAL FUNCTIONS WORK CORRECTLY.



A) Remove original exhaust from bike, taking care to keep all original components in a safe place.

B) Refit Scorpion exhaust as per line diagram above.

C) When fitted take bike for a short ride to ensure all functions are correct.

D) When bike & exhaust are cool enough check all nuts and bolts are still secure.

Cleaning instructions overleaf:

Box: PLOCK 1

BIKE	HONDA CBF 1000	PART NO.	RHA - 106
YEAR	2010 - ON	FIT KITS	Z039.20447
NOTES		FEATURES	DB KILLER Z038.10043(V)

Thank you for purchasing your Scorpion Silencer.

Care of your exhaust: Please refrain from cleaning silencer with heavy solvents or abrasives!

Vielen Dank Für den kauf eines Scorpion Schalldampfers! Pflegehinweis: Bitte verwenden Sie niemals Scheuermittel oder aggressive Reiniger zur Pflege Ihres Auspuffes!

Merci d'avoir choisi un echappement Scorpion.

Entretien de votre silencieux: Ne pas utiliser de solvants ou de produits abrasifs!

"Muchas gracias por adquirir un Silencioso Scorpion. Le recomendamos no limpiar el silencioso con productos abrasivos o aquellos que contengan disolventes."

